

CB 25

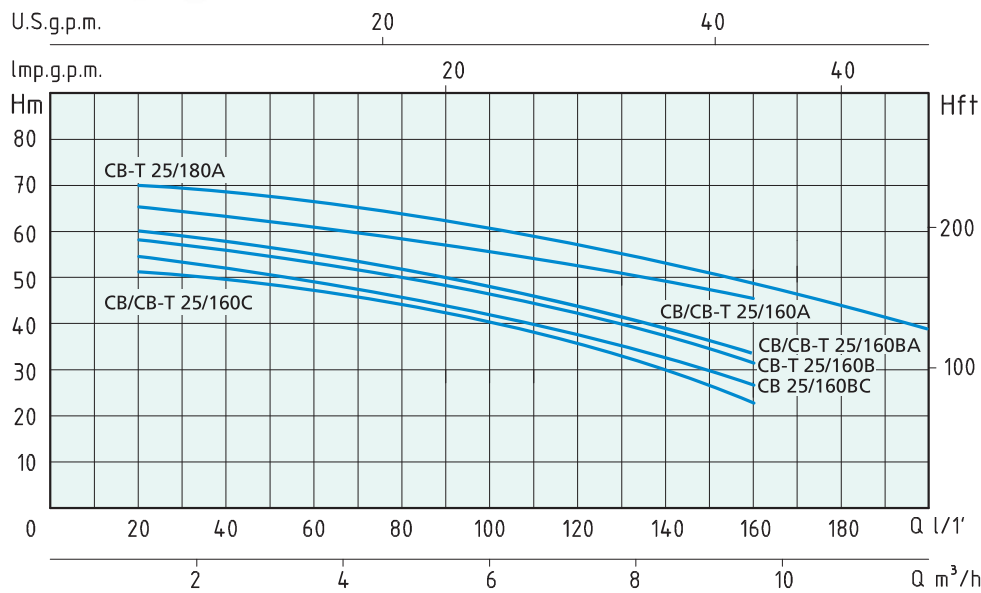
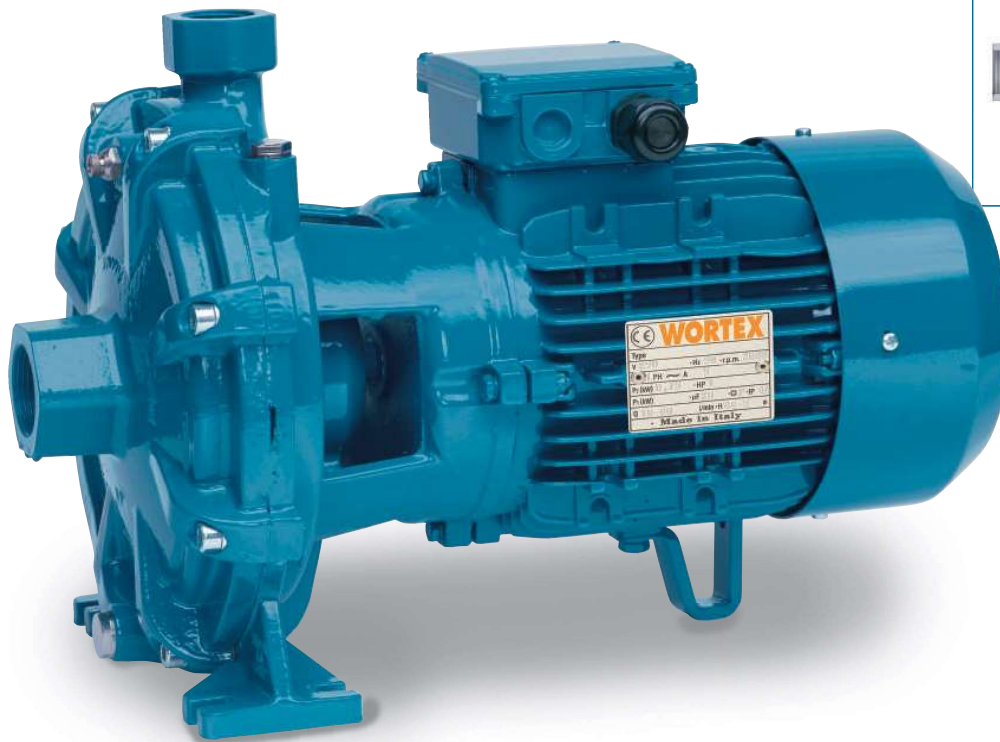

TIPO TYPE		POTENZA NOMINALE NOMINAL POWER		POTENZA ASSORBITA INPUT POWER	AMPERE		Q = PORTATA - CAPACITY											
Monofase Single-phase	Trifase Three-phase	P2		P1	Monofase Single-phase	Trifase Three-phase	m³/h	1,2	2,4	3,6	4,8	6	7,2	8,4	9,6	10,8	12	
230V-50Hz	230/400V-50Hz	HP	kW	kW	1 x 230V	3 x 400V	lt/1'	20	40	60	80	100	120	140	160	180	200	
CB 25/160C	CB-T 25/160C	1,5	1,1	2,2	10	4,3	H (m)	51	49	47	44	40	35	27	23			
CB 25/160BC		2	1,5	2,4	11			54	52	49	46	42	36	28	26			
	CB-T 25/160B	2	1,5	2,6		5		58	56	53,5	50	47,5	42	35	31			
CB 25/160BA	CB-T 25/160BA	2,5	1,85	2,8	13	5,2		61	59	57	54	48	42	35	33			
CB 25/160A	CB-T 25/160A	3	2,2	3,6	16	5,7		65	62,5	61	59	57	54	50,5	46			
								Prevalenza manometrica totale in m.C.A. - Total head in meters w.c.										

ELETTROPOMPE CENTRIFUGHE BIGIRANTI TWIN IMPELLER CENTRIFUGAL PUMPS

WORTEX

APPLICAZIONI

Elettropompe centrifughe bigiranti per sollevare acqua pulita e liquidi moderatamente carichi di impurità non aggressivi per i materiali delle pompe. Caratteristica principale è l'impiego di due giranti contrapposte che permettono, a differenza del modello monogirante, elevate prevalenze. Adatte per impianti civili e industriali, distribuzione automatica dell'acqua a mezzo di piccoli-medi serbatoi (autoclave) e per irrigazione a pioggia in giardino e in agricoltura.

LIMITI D'IMPIEGO

- Temperatura liquido fino a 35°C (per un uso domestico secondo EN 60335-2-41)
- Temperatura max. liquido: 90°C (per altri impieghi)
- Temperatura ambiente fino a 40°C
- Altezza d'aspirazione manometrica fino a 7 mt.
- Servizio continuo

MOTORE

- Motore elettrico ad induzione a 2 poli (n = 2850 min⁻¹)
- Isolamento Classe F
- Protezione IP 55

MATERIALI

- Corpo pompa Ghisa
- Supporto motore Ghisa
- Giranti Ottone
- Albero motore Acciaio Inox AISI 304
- Tenute meccaniche Ceramica/Grafite/NBR

APPLICATION

Twin impeller centrifugal water pumps to lift clean water and non-aggressive liquids. The main feature are the two opposite impellers which allow higher lifts than in the single-impeller model. They are qualified for civil and industrial fittings, for water distribution by tank pressure groups and for irrigation in gardening and agriculture.

OPERATING CONDITIONS

- Liquid temperature up to 35°C (for home use according to EN 60335-2-41)
- Temperature max. liquid: 90°C (for other uses)
- Ambient temperature up to 40°C
- Total suction lift up to 7 mt.
- Continuous duty

MOTOR

- Two-Pole induction motor (n = 2850 min⁻¹)
- Insulation Class F
- Protection IP 55

MATERIALS

- Pump body Cast Iron
- Motor Support Cast Iron
- Impellers Brass
- Shaft with rotor Stainless Steel AISI 304
- Mechanical seal Ceramic/Graphite/NBR

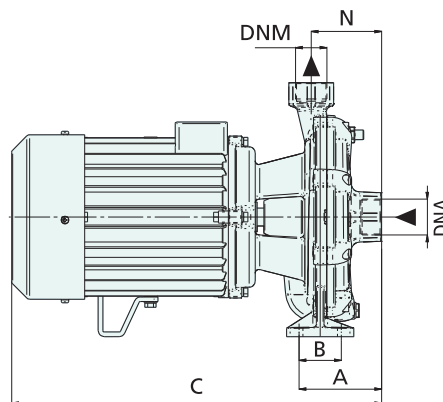
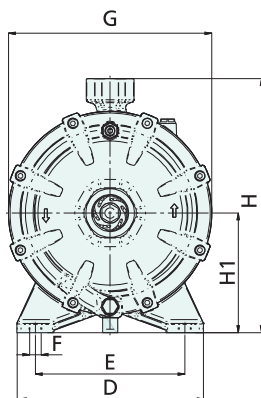

TIPO TYPE		DIMENSIONI mm - DIMENSIONS mm											DIMENSIONI DIMENSIONS mm			PESO WEIGHT	
Monofase Single-phase	Trifase Three-phase	A	B	C	D	E	F	G	H	H1	N	DNA	DNM	P	L	H	Kg
CB 25/160C	CB-T 25/160C	95	50	400	208	168	10	222	265	120	85	1" 1/4	1"	240	414	314	24,6
CB 25/160BC		95	50	432	208	168	10	222	265	120	85	1" 1/4	1"	240	414	314	26,4
	CB-T 25/160B	95	50	432	208	168	10	222	265	120	85	1" 1/4	1"	240	414	314	24,6
CB 25/160BA	CB-T 25/160BA	95	46	432	208	168	10	222	265	120	85	1" 1/4	1"	259	507	345	29,9
CB 25/160A	CB-T 25/160A	108,5	46	440	230	190	12	246	290	132	92,5	1" 1/4	1"	259	507	345	36,1